

# TRIPLEX CORK LINE STACKER FL-112



## THE PROBLEMS WITH BIG AND HEAVY CORK LINE ARE SOLVED

**TRIPLEX CORK LINE STACKER FL-112 stacks the cork line effectively without manual help.**

**The Cork line Stacker is operated by one man with a radiocontrol, no handhandling required !**

### TECHNICAL DATA:

Max.hauling power	150 kp	Required oil flow	50 l/min
Max.slewing radius	4,50 m	Working pressure	200 bar
Slewing torque crane	1000 kpm	Weight without column	1150-1300 kgs
Slewing torque roller unit	90 kpm	Weight column	150 kgs/m
Required power for pump	18 kw		



## **TRIPLEX AS**

HENDA, N-6530 AVERØY, NORWAY

Phone: (47) 71 51 39 00 • Fax: (47) 71 51 39 01

E-mail: [post@triplex.no](mailto:post@triplex.no) [www.triplex.no](http://www.triplex.no)

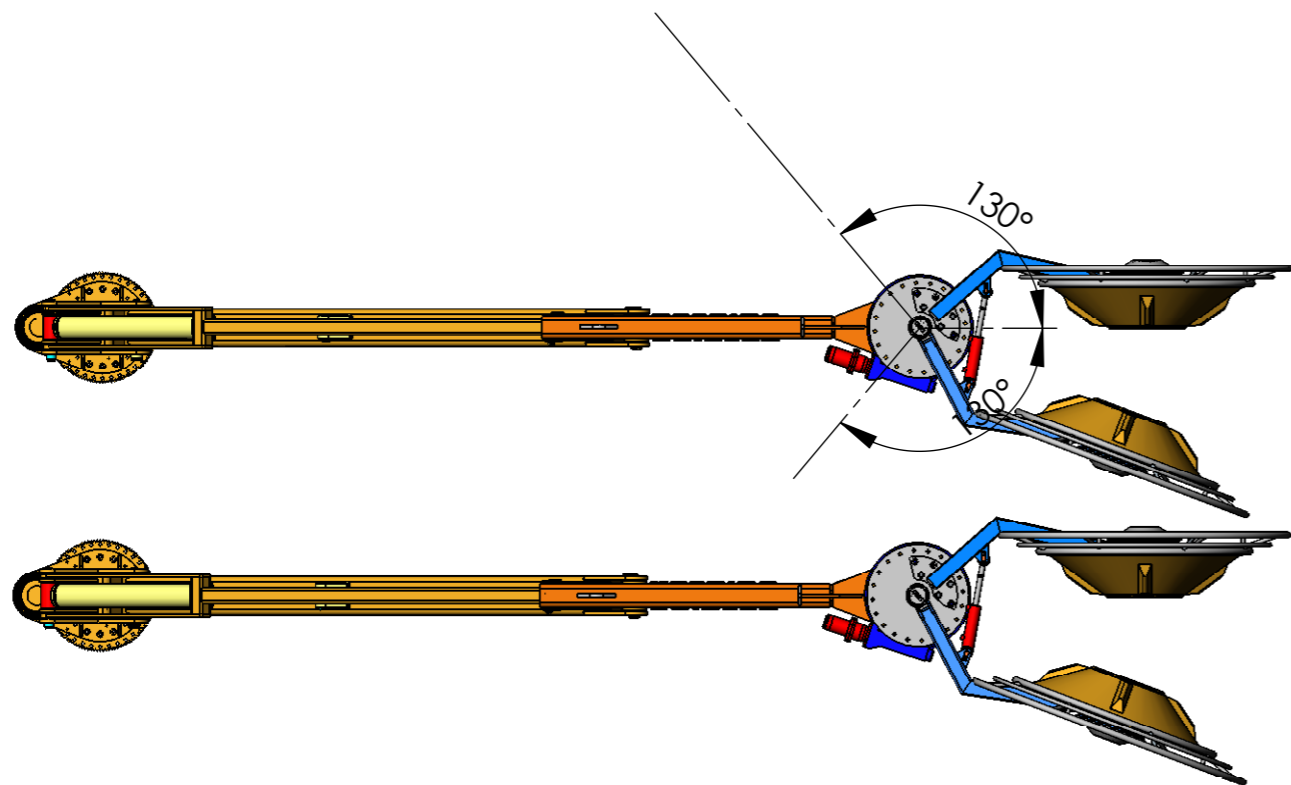
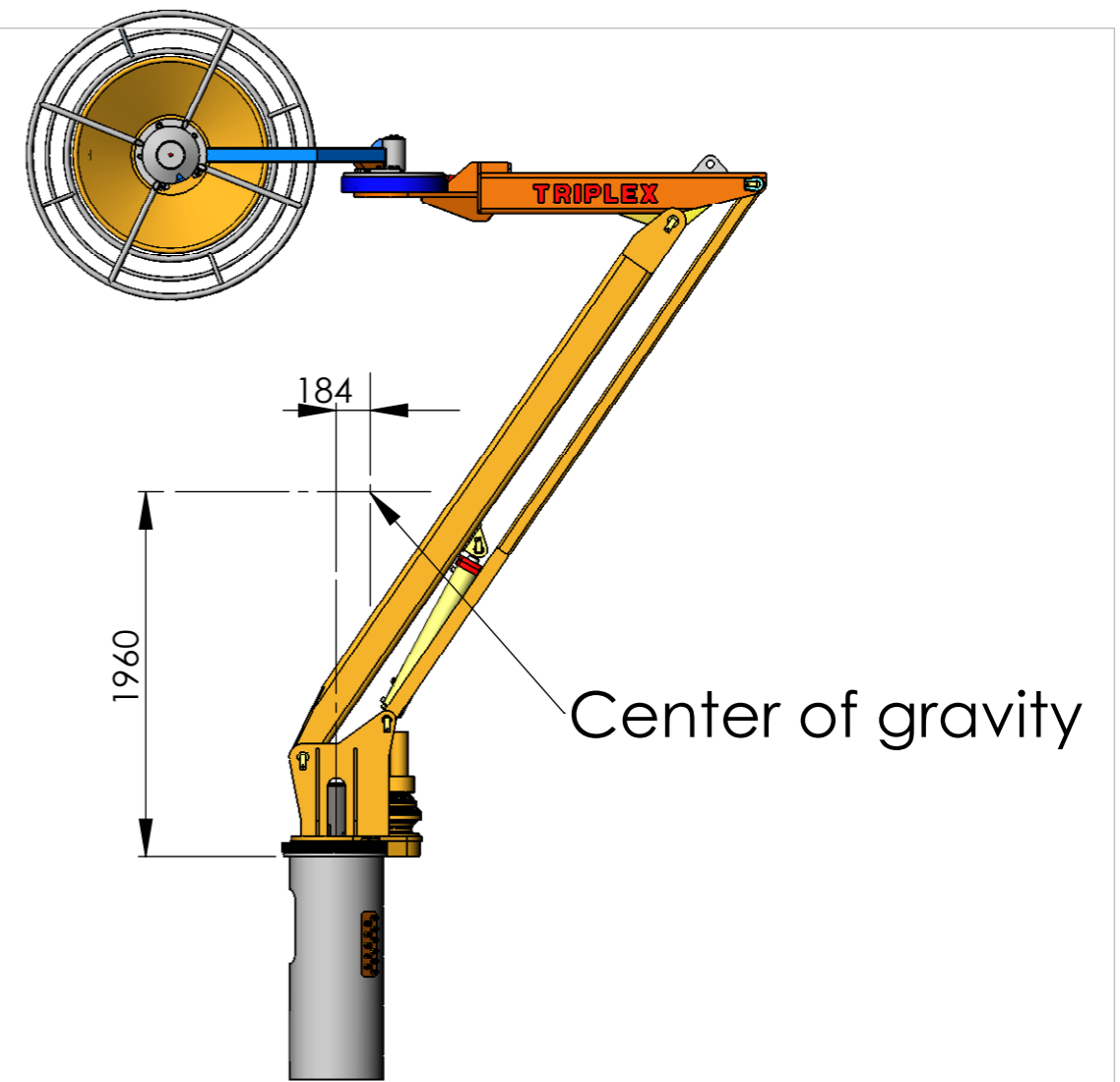
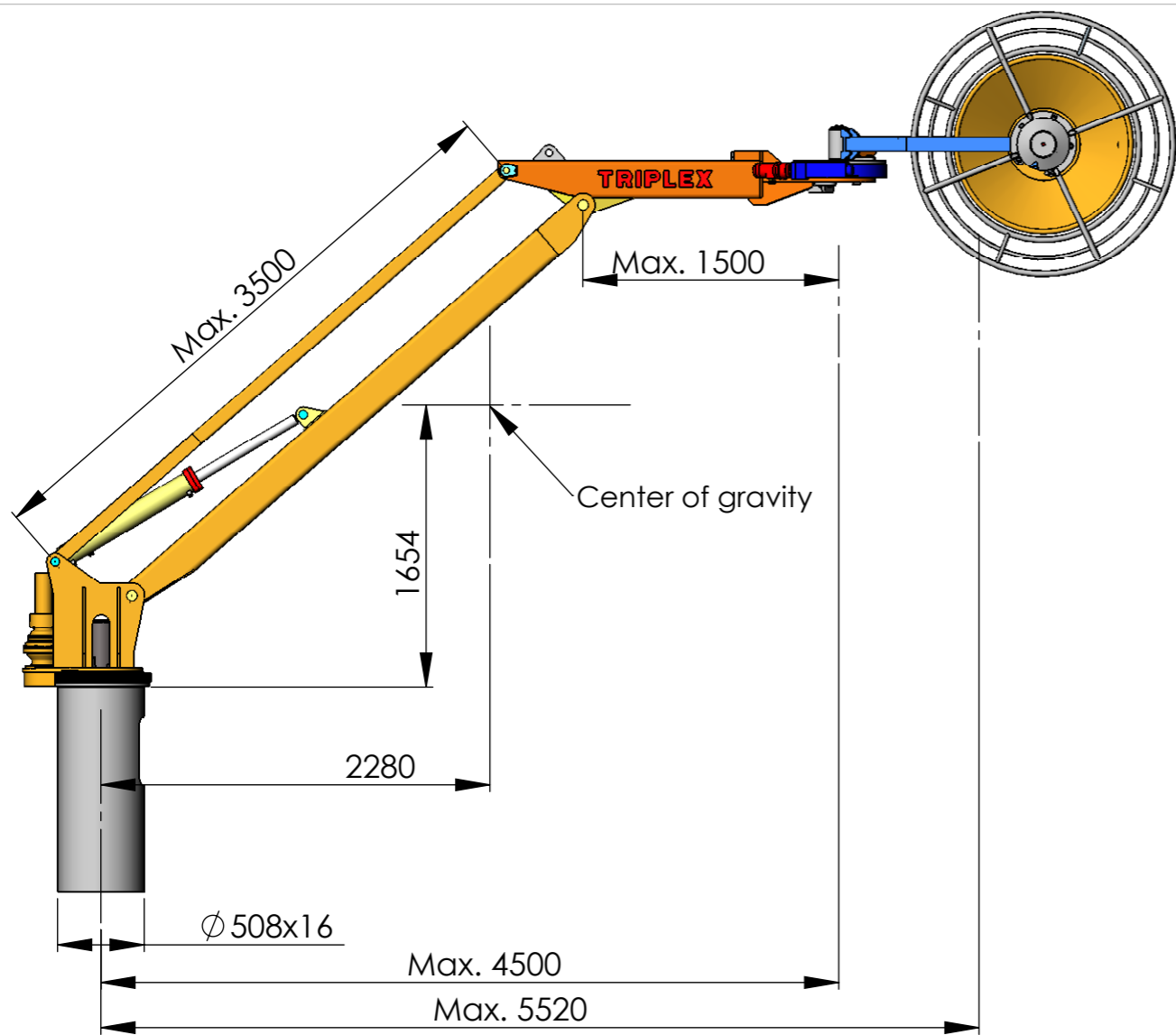

- Max working radius 5,52 m
- Turning angle 360 deg
- Working head slewing torque 1500 Nm
- Working head turning angle 260 deg
- Working pressure 200 bar
- Recommended oil supply 45 l/min
- Required powers for oil pump 18 kW
- Max. Hauling power roller 1500 N
- Slewing torque crane 10 kNm
- Weight without foundation approx. 1155 kg
- Weight foundation approx. 210 kg/m

TRIPLEX CORK LINE STACKER  
FL-112\35\15  
DIMENSION SKETCH

Scale	Unspec. tolerances in compliance with	Weight (kg)	1475.0 kg
1:40		Date	28.09.2001
Format		Drawn by	FG
A3		Replaces:	
Drawing no.	Version	Projection	
1873B	1		
Part no.	Replaced by:		

**TRIPLEX AS**  
HENDA, N-6530 AVERØY, NORWAY  
Phone: (47) 71 51 39 00 • Fax: (47) 71 51 39 01  
E-mail: post@triplex.no www.triplex.no